



**WYSOKOJAKOŚCIOWE  
NARZĘDZIA SKRAWAJĄCE**

**CENNIK PRODUKTÓW**  
ważny od 1.01.2019



w w w . b a u s m e t . p l

Ø mm	opak. szt.	PLN netto/szt.	kod
M3x0,5	1	15,50 zł	3101 0030
M4x0,7	1	15,50 zł	3101 0040
M5x0,8	1	15,90 zł	3101 0050
M6x1,0	1	15,90 zł	3101 0060
M8x1,25	1	18,97 zł	3101 0080
M10x1,5	1	24,27 zł	3101 0100
M12x1,75	1	30,95 zł	3101 0120
M14x2,0	1	34,87 zł	3101 0140
M16x2,0	1	55,54 zł	3101 0160
M18x2,5	1	57,66 zł	3101 0180
M20x2,5	1	59,78 zł	3101 0200
M22x2,5	1	103,88 zł	3101 0220
M24x3,0	1	105,05 zł	3101 0240

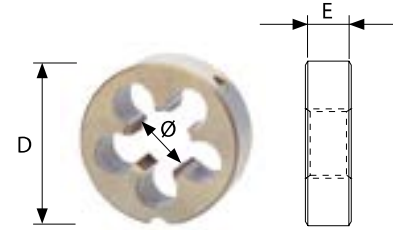

Ø mm	opak. szt.	PLN netto/szt.	kod
MF6x0,5	1	15,90 zł	3101 0060 050
MF6x0,75	1	15,90 zł	3101 0060 075
MF8x0,5	1	18,97 zł	3101 0080 050
MF8x0,75	1	18,97 zł	3101 0080 075
MF8x1,0	1	18,97 zł	3101 0080 100
MF10x0,75	1	24,27 zł	3101 0100 075
MF10x1,0	1	24,27 zł	3101 0100 100
MF10x1,25	1	24,27 zł	3101 0100 125
MF12x1,0	1	30,95 zł	3101 0120 100
MF12x1,25	1	30,95 zł	3101 0120 125
MF12x1,5	1	30,95 zł	3101 0120 150
MF14x1,0	1	34,87 zł	3101 0140 100
MF14x1,25	1	34,87 zł	3101 0140 125
MF14x1,5	1	34,87 zł	3101 0140 150
MF16x1,0	1	55,54 zł	3101 0160 100
MF16x1,5	1	55,54 zł	3101 0160 150
MF18x1,5	1	57,66 zł	3101 0180 150
MF20x1,0	1	59,78 zł	3101 0200 100
MF20x1,5	1	59,78 zł	3101 0200 150
MF20x2,0	1	59,78 zł	3101 0200 200
MF22x1,5	1	103,88 zł	3101 0220 150
MF24x1,5	1	105,05 zł	3101 0240 150
MF24x2,0	1	105,05 zł	3101 0240 200

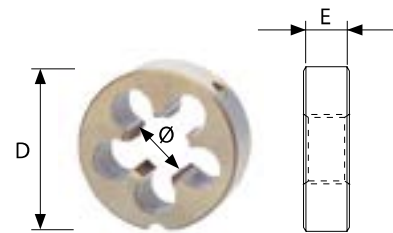

Ø mm	opak. szt.	PLN netto/szt.	kod
G1/8	1	35,36 zł	3120 0180
G1/4	1	54,08 zł	3120 0140
G3/8	1	96,48 zł	3120 0380
G1/2	1	96,48 zł	3120 0120
G3/4	1	155,36 zł	3120 0340
G1	1	211,84 zł	3120 1000

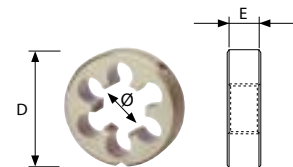

Ø mm	opak. szt.	PLN netto/szt.	kod
M3x0,5	1	21,90 zł	3001 0030
M4x0,7	1	21,90 zł	3001 0040
M5x0,8	1	22,60 zł	3001 0050
M6x1,0	1	24,00 zł	3001 0060
M7x1,0	1	25,90 zł	3001 0070
M8x1,25	1	28,60 zł	3001 0080
M10x1,5	1	38,60 zł	3001 0100
M12x1,75	1	53,00 zł	3001 0120
M14x2,0	1	73,30 zł	3001 0140
M16x2,0	1	88,30 zł	3001 0160
M18x2,5	1	123,90 zł	3001 0180
M20x2,5	1	136,30 zł	3001 0200
M22x2,5	1	159,80 zł	3001 0220
M24x3,0	1	177,70 zł	3001 0240

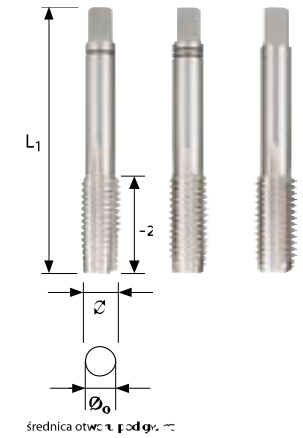

Ø mm	opak. szt.	PLN netto/szt.	kod
MF6x0,5	1	24,00 zł	3001 0060 050
MF6x0,75	1	24,00 zł	3001 0060 075
MF8x0,5	1	28,60 zł	3001 0080 050
MF8x0,75	1	28,60 zł	3001 0080 075
MF8x1,0	1	28,60 zł	3001 0080 100
MF10x0,75	1	38,60 zł	3001 0100 075
MF10x1,0	1	38,60 zł	3001 0100 075
MF10x1,25	1	38,60 zł	3001 0100 125
MF12x1,0	1	53,00 zł	3001 0120 100
MF12x1,25	1	53,00 zł	3001 0120 125
MF12x1,5	1	53,00 zł	3001 0120 150
MF14x1,0	1	73,30 zł	3001 0140 100
MF14x1,25	1	73,30 zł	3001 0140 125
MF14x1,5	1	73,30 zł	3001 0140 150
MF16x1,0	1	88,30 zł	3001 0160 100
MF16x1,5	1	88,30 zł	3001 0160 150
MF18x1,5	1	123,90 zł	3001 0180 150
MF20x1,0	1	136,30 zł	3001 0200 100
MF20x1,5	1	136,30 zł	3001 0200 150
MF20x2,0	1	136,30 zł	3001 0200 200
MF22x1,5	1	159,80 zł	3001 0220 150
MF24x1,5	1	177,70 zł	3001 0240 150
MF24x2,0	1	177,70 zł	3001 0240200

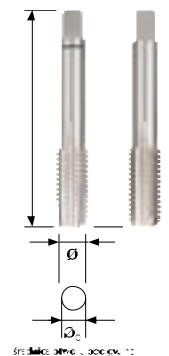

Ø mm	opak. szt.	PLN netto/szt.	kod
G1/8	1	43,52 zł	3020 0180
G1/4	1	64,27 zł	3020 0140
G3/8	1	79,09 zł	3020 0380
G1/2	1	130,81 zł	3020 0120
G3/4	1	235,40 zł	3020 0340
G1	1	361,30 zł	3020 1000



**GWINTOWNIKI MASZYNOWE DIN 371/376**
M C HSS

 seria **3503/3507**

Ø mm	opak. szt.	PLN netto/szt.	kod
M3x0,5	1	23,50	3503 0030
M4x0,7	1	20,70	3503 0040
M5x0,8	1	20,70	3503 0050
M6x1,0	1	22,30	3503 0060
M8x1,25	1	23,80	3503 0080
M10x1,5	1	32,40	3503 0100
M12x1,75	1	42,70	3507 0120
M16x2,0	1	58,90	3507 0160
M20x2,5	1	87,50	3507 0200

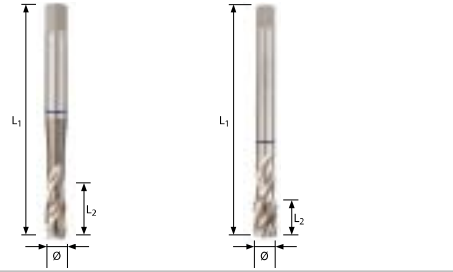
**GWINTOWNIKI MASZYNOWE DIN 371/376**
M C HSS TiN

 seria **3513/3517**

Ø mm	opak. szt.	PLN netto/szt.	kod
M3x0,5	1	30,88	3513 0030
M4x0,7	1	28,08	3513 0040
M5x0,8	1	30,78	3513 0050
M6x1,0	1	32,38	3513 0060
M8x1,25	1	36,22	3513 0080
M10x1,5	1	46,80	3513 0100
M12x1,75	1	60,52	3517 0120
M16x2,0	1	86,80	3517 0160
M20x2,5	1	126,92	3517 0200

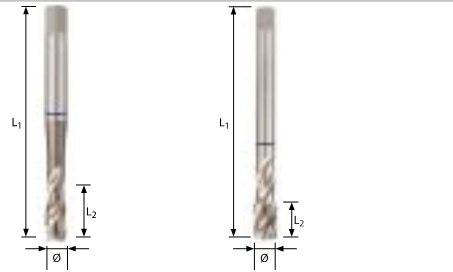
**GWINTOWNIKI MASZYNOWE DIN 371/376**
M C HSSE Co 5

 seria **3504/3508**

Ø mm	opak. szt.	PLN netto/szt.	kod
M3x0,5	1	30,80	3504 0030
M4x0,7	1	30,80	3504 0040
M5x0,8	1	30,80	3504 0050
M6x1,0	1	32,80	3504 0060
M8x1,25	1	38,40	3504 0080
M10x1,5	1	53,70	3504 0100
M12x1,75	1	64,70	3508 0120
M16x2,0	1	95,10	3508 0160
M20x2,5	1	153,60	3508 0200

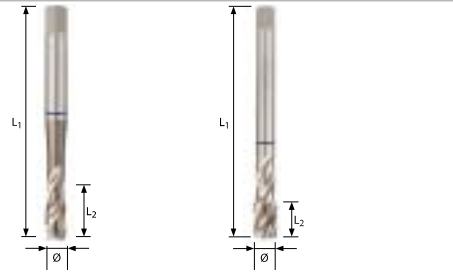
**GWINTOWNIKI MASZYNOWE DIN 371/376**
M C HSSE Co 5 TiCN

 seria **3514/3518**

Ø mm	opak. szt.	PLN netto/szt.	kod
M3x0,5	1	38,18	3514 0030
M4x0,7	1	38,18	3514 0040
M5x0,8	1	40,88	3514 0050
M6x1,0	1	42,88	3514 0060
M8x1,25	1	50,82	3514 0080
M10x1,5	1	68,10	3514 0100
M12x1,75	1	82,52	3518 0120
M16x2,0	1	123,00	3518 0160
M20x2,5	1	193,02	3518 0200

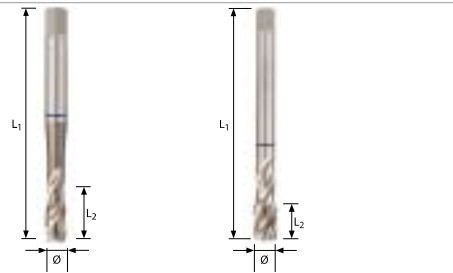

w w w . b a u s m e t . p l

**GWINTOWNIKI MASZYNOWE DIN 371/376**
M B HSS

 seria **3501/3505**

Ø mm	opak. szt.	PLN netto/szt.	kod
M3x0,5	1	22,80	3501 0030
M4x0,7	1	20,10	3501 0040
M5x0,8	1	20,10	3501 0050
M6x1,0	1	21,60	3501 0060
M8x1,25	1	23,10	3501 0080
M10x1,5	1	31,50	3501 0100
M12x1,75	1	41,50	3505 0120
M16x2,0	1	57,20	3505 0160
M20x2,5	1	84,90	3505 0200

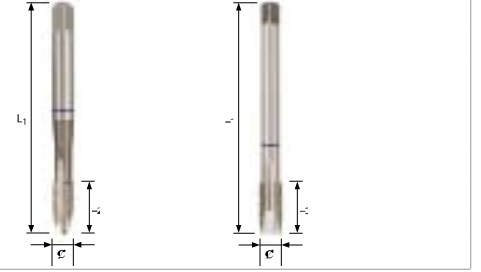
**GWINTOWNIKI MASZYNOWE DIN 371/376**
M B HSS TiN

 seria **3511/3515**

Ø mm	opak. szt.	PLN netto/szt.	kod
M3x0,5	1	30,18	35110030
M4x0,7	1	27,48	35110040
M5x0,8	1	30,18	35110050
M6x1,0	1	31,68	35110060
M8x1,25	1	35,52	35110080
M10x1,5	1	45,90	35110100
M12x1,75	1	59,32	35150120
M16x2,0	1	85,10	35150160
M20x2,5	1	124,32	35150200

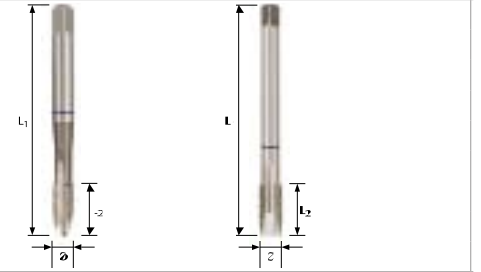
**GWINTOWNIKI MASZYNOWE DIN 371/376**
M B HSSE Co 5

 seria **3502/3506**

Ø mm	opak. szt.	PLN netto/szt.	kod
M3x0,5	1	28,80	3502 0030
M4x0,7	1	28,80	3502 0040
M5x0,8	1	28,80	3502 0050
M6x1,0	1	30,70	3502 0060
M8x1,25	1	35,90	3502 0080
M10x1,5	1	44,70	3502 0100
M12x1,75	1	49,70	3506 0120
M16x2,0	1	73,20	3506 0160
M20x2,5	1	139,60	3506 0200

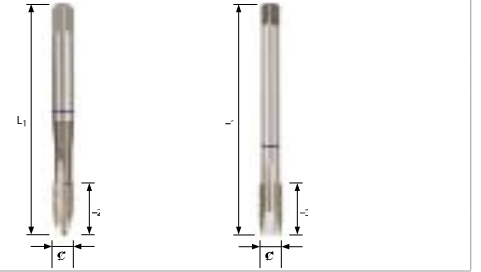
**GWINTOWNIKI MASZYNOWE DIN 371/376**
M B HSSE Co 5 TiCN

 seria **3512/3516**

Ø mm	opak. szt.	PLN netto/szt.	kod
M3x0,5	1	36,18	3512 0030
M4x0,7	1	36,18	3512 0040
M5x0,8	1	38,88	3512 0050
M6x1,0	1	40,78	3512 0060
M8x1,25	1	48,32	3512 0080
M10x1,5	1	59,10	3512 0100
M12x1,75	1	67,52	3516 0120
M16x2,0	1	101,10	3516 0160
M20x2,5	1	179,02	3516 0200

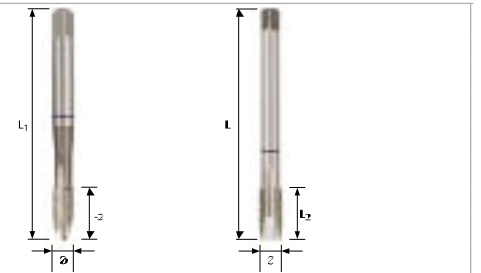

w w w . b a u s m e t . p l

**GWINTOWNIKI DO NAKRĘTEK DIN 357**

M HSS

seria **3060**

Ø mm	opak. szt.	PLN netto/szt.	kod
M3x0,5	1	21,06	3060 0030
M4x0,7	1	21,06	3060 0040
M5x0,8	1	24,02	3060 0050
M6x1,0	1	28,70	3060 0060
M8x1,25	1	34,48	3060 0080
M10x1,5	1	43,52	3060 0100
M12x1,75	1	50,54	3060 0120
M16x2,0	1	74,57	3060 0160



**GWINTOWNIKI MASZYNOWE DIN 374**

MF B HSS TIN

seria **3611**

Ø mm	opak. szt.	PLN netto/szt.	kod
MF6x0,75	1	24,04	3611 0060 075
MF8x1,0	1	27,38	3611 0080 100
MF10x1,0	1	31,77	3611 0100 100
MF10x1,25	1	31,77	3611 0100 125
MF12x1,0	1	43,17	3611 0120 100
MF12x1,25	1	43,17	3611 0120 125
MF12x1,5	1	43,17	3611 0120 150
MF16x1,5	1	60,20	3611 0160 150
MF20x1,5	1	96,35	3611 0200 150
MF20x2,0	1	96,35	3611 0200 200

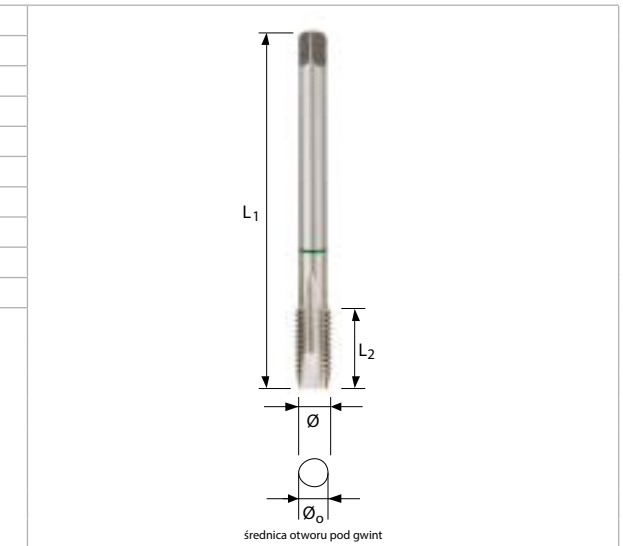

**GWINTOWNIKI KOMBI LONG**

M HSS

seria **3070**

Ø mm	opak. szt.	PLN netto/szt.	kod
M3x0,5	1	28,12	3070 0030
M4x0,7	1	28,12	3070 0040
M5x0,8	1	28,12	3070 0050
M6x1,0	1	28,12	3070 0060
M8x1,25	1	34,67	3070 0080
M10x1,5	1	45,86	3070 0100

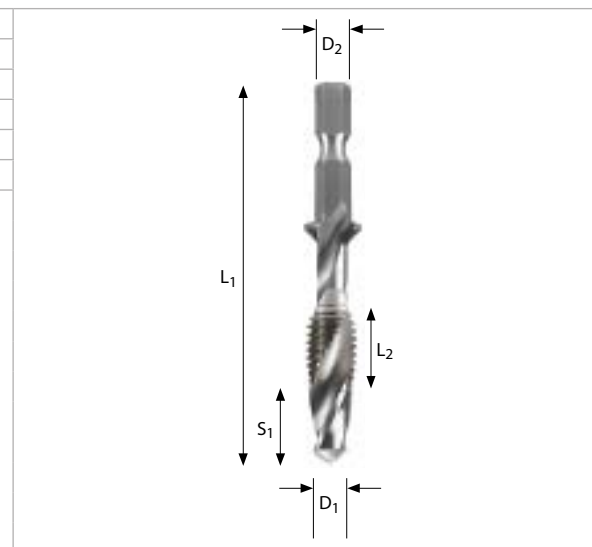

**GWINTOWNIKI MASZYNOWE DIN 374 R35**

MF C HSS TIN

seria **3613**

Ø mm	opak. szt.	PLN netto/szt.	kod
MF6x0,75	1	25,10	3613 0060 075
MF8x1,0	1	28,61	3613 0080 100
MF10x1,0	1	33,17	3613 0100 100
MF10x1,25	1	33,17	3613 0100 125
MF12x1,0	1	46,86	3613 0120 100
MF12x1,25	1	46,86	3613 0120 125
MF12x1,5	1	46,86	3613 0120 150
MF16x1,5	1	64,06	3613 0160 150
MF20x1,5	1	101,09	3613 0200 150
MF20x2,0	1	101,09	3613 0200 200

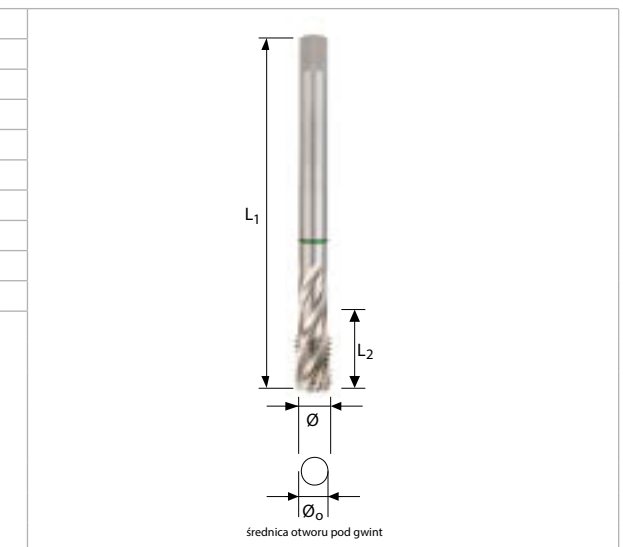

Ø mm	opak. szt.	PLN netto/szt.	kod
4-12x9	1	44,00	1601 0010
4-20x9	1	67,00	1601 0020
4-30x14	1	120,00	1601 0030
6-38x12	1	230,00	1601 0040



Ø mm	opak. szt.	PLN netto/szt.	kod
4-12x9	1	63,80	1611 0010
4-20x9	1	110,80	1611 0020
4-30x14	1	200,40	1611 0030
6-38x12	1	320,00	1611 0040



Ø mm	opak. szt.	PLN netto/szt.	kod
4-12x9	1	86,50	1612 0010
4-20x9	1	160,30	1612 0020
4-30x14	1	284,50	1612 0030
6-38x12	1	410,00	1612 0040



Ø mm	opak. szt.	PLN netto/szt.	kod
6,3	1	26,00	1801 0630
8,3	1	29,00	1801 0830
10,4	1	35,00	1801 1040
12,4	1	37,00	1801 1240
15,0	1	40,00	1801 1500
16,5	1	46,00	1801 1650
20,5	1	62,00	1801 2050
25	1	85,00	1801 2500
31	1	116,00	1801 3100

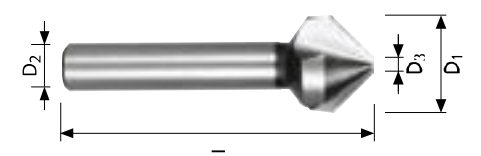

Ø mm	opak. szt.	PLN netto/szt.	kod
6,3	1	39,80	1811 0630
8,3	1	45,00	1811 0830
10,4	1	54,80	1811 1040
12,4	1	64,00	1811 1240
15,0	1	74,00	1811 1500
16,5	1	80,80	1811 1650
20,5	1	113,10	1811 2050
25	1	151,80	1811 2500
31	1	196,40	1811 3100

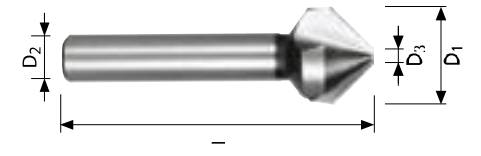

Ø mm	opak. szt.	PLN netto/szt.	kod
6,3	1	41,80	1812 0630
8,3	1	46,60	1812 0830
10,4	1	60,20	1812 1040
12,4	1	66,80	1812 1240
15,0	1	75,80	1812 1500
16,5	1	90,80	1812 1650
20,5	1	129,60	1812 2050
25	1	167,20	1812 2500
31	1	209,40	1812 3100

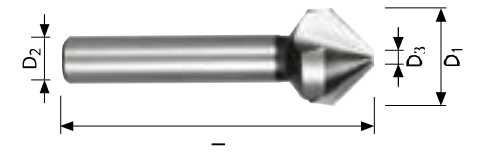

Ø mm	opak. szt.	PLN netto/szt.	kod
6,3	1	30,00	1802 0630
8,3	1	35,00	1802 0830
10,4	1	40,00	1802 1040
12,4	1	44,00	1802 1240
15,0	1	47,00	1802 1500
16,5	1	51,00	1802 1650
20,5	1	75,00	1802 2050
25	1	103,00	1802 2500
31	1	145,00	1802 3100

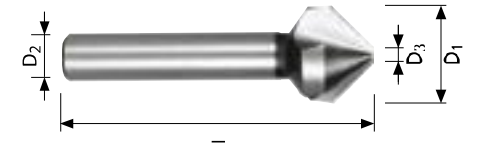

Ø mm	opak. szt.	PLN netto/szt.	kod
6,3	1	45,80	1822 0630
8,3	1	52,60	1822 0830
10,4	1	65,20	1822 1040
12,4	1	73,80	1822 1240
15,0	1	81,20	1822 1500
16,5	1	95,80	1822 1650
20,5	1	142,60	1822 2050
25	1	185,20	1822 2500
31	1	238,40	1822 3100

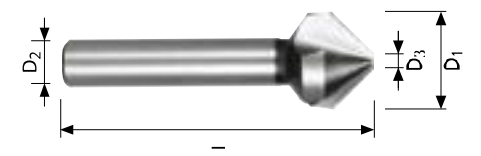

**PILNIKI OBROTOWE**

**BMM PLUS** szerokie zastosowanie **seria 2020,2022**

- wysokodajne pilniki obrotowe z uzębieniem typu PLUS mają bardzo szerokie zastosowanie:
  - żeliwo → stal <60HRC → stal nierdzewna INOX → stopy na bazie niklu i tytanu
- bardzo dobra relacja pomiędzy szybkością pracy i jakością uzyskiwanej powierzchni
- szeroka oferta kształtów
- trzcień 6mm

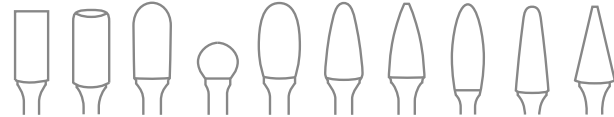
**BMM STRONG** stworzone dla stali i staliwa **seria 2080**

- wysokowydajne pilniki obrotowe z uzębieniem typu STRONG zalecane są do obróbki zgrubnej
- wydajność do 50% większa w stosunku do standardowych pilników przy pracy na stali i staliwie
- agresywna szybka obróbka → duże wióry → bardzo dobre odprowadzenie wióra
- trzcień 8mm

kod	Nazwa	PLN netto/szt.
208001105	ZYA 12,0x25x70x8mm PILNIK OBROTOWY HM WALEC STRONG	70,00
208021105	WRC 12,0x25x70x8mm PILNIK OBROTOWY HM WALEC zaokr. STRONG	75,00
208051050	RBF 12,0x25x70x8mm PILNIK OBROTOWY HM OSTROŁUKOWY zaokr. STRONG	75,00
208081045	KEL 12,0x28x73x8mm PILNIK OBROTOWY HM STOŻKOWY zaokr. STRONG	75,00

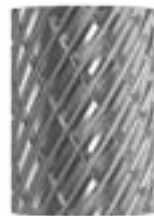
**BMM CAST** stworzone dla żeliwa **seria 2090**

- wysokowydajne pilniki obrotowe z uzębieniem typu CAST zalecane są do obróbki zgrubnej żeliwa
- ekstremalnie wysoka wydajność skrawania przy pracy na żeliwie, do 100% wyższa w porównaniu do standardowych pilników
- agresywna szybka obróbka → duże wióry → bardzo dobre odprowadzenie wióra
- trzcień 8mm

kod	Nazwa	PLN netto/szt.
209081045	KEL 12,0x32x77x8mm PILNIK OBROTOWY HM STOŻKOWY zaokr. CAST	85,00

Wzmocniona konstrukcja ostrzy pilników typu STRONG I CAST daje dodatkowo możliwość prowadzenia obróbki przy większym nacisku, wywołując skrawanie grubszej warstwy materiału, co znacząco zwiększa objętość usuwanego materiału i szybkość obróbki.

**POWŁOKA XT-3300**

Kolor	FIOLETOWY
Zastosowanie	→ Stal nierdzewna → stal 45-65 HRC → żeliwo szare → żeliwo sferoidalne Ti → stopy, Ti
Struktura powłoki	Monowarstwowa
Grubość powłoki (µm)	1-4
Mikrotwardość (HV0,05)	3.300
Współczynnik tarcia o stal na sucho	0,4
Max. temp. zastosowania (°C)	900
Chłodzenie	Obróbka na sucho
Zalety	→ bardzo wysoka twardość na gorąco → bardzo wysoka odporność na utlenianie → wydłużona żywotność narzędzia → maksymalnie wysoka prędkość pracy

**PILNIKI OBROTOWE**
**seria 2020** **seria 2022**  
z powłoką TiAlN

Ø mm	opak. szt.		kod	PLN netto/szt.	kod	PLN netto/szt.
6,0	1	ZYA	2020 01065	29,00	2022 01065	41,77
8,0	1	ZYA	2020 01080	39,00	2022 01080	53,84
10,0	1	ZYA	2020 01090	43,00	2022 01090	58,30
12,0	1	ZYA	2020 01105	66,00	2022 01105	88,17
16,0	1	ZYA	2020 01120	94,00	2022 01120	116,82
6,0	1	ZYA	2020 11050	35,00	2022 11050	45,19
8,0	1	ZYA	2020 11075	45,00	2022 11075	57,26
10,0	1	ZYA	2020 11085	46,00	2022 11085	59,44
12,0	1	ZYA	2020 11100	74,00	2022 11100	91,59
16,0	1	ZYA	2020 11115	99,00	2022 11115	125,94
6,0	1	WRC	2020 21055	33,00	2022 21055	47,47
8,0	1	WRC	2020 21075	43,00	2022 21075	57,26
10,0	1	WRC	2020 21085	45,00	2022 21085	62,86
12,0	1	WRC	2020 21105	69,00	2022 21105	95,00
16,0	1	WRC	2020 21120	99,00	2022 21120	128,21
6,0	1	KUD	2020 31055	31,00	2022 31055	41,20
8,0	1	KUD	2020 31060	33,00	2022 31060	44,73
10,0	1	KUD	2020 31070	37,00	2022 31070	50,33
12,0	1	KUD	2020 31080	52,00	2022 31080	69,94
16,0	1	KUD	2020 31095	67,00	2022 31095	96,32
6,0	1	TRE	2020 41020	43,00	2022 41020	53,20
8,0	1	TRE	2020 41025	47,00	2022 41025	59,95
10,0	1	TRE	2020 41030	48,00	2022 41030	60,58
12,0	1	TRE	2020 41035	68,00	2022 41035	85,52
16,0	1	TRE	2020 41045	99,00	2022 41045	129,95
6,0	1	RBF	2020 51030	39,00	2022 51030	54,30
8,0	1	RBF	2020 51035	45,00	2022 51035	61,82
10,0	1	RBF	2020 51040	47,00	2022 51040	60,58
12,0	1	RBF	2020 51050	69,00	2022 51050	89,31
16,0	1	RBF	2020 51065	98,00	2022 51065	130,49
6,0	1	SPG	2020 61035	42,00	2022 61035	52,02
8,0	1	SPG	2020 61040	46,00	2022 61040	58,40
10,0	1	SPG	2020 61045	48,00	2022 61045	61,72
12,0	1	SPG	2020 61060	67,00	2022 61060	84,75
16,0	1	SPG	2020 61085	99,00	2022 61085	128,21
6,0	1	PŁO	2020 71010	44,00	2022 71010	54,30
8,0	1	PŁO	2020 71015	50,00	2022 71015	61,82
10,0	1	PŁO	2020 71020	47,00	2022 71020	60,58
12,0	1	PŁO	2020 71030	71,00	2022 71030	89,31
16,0	1	PŁO	2020 71035	109,00	2022 71035	130,49
6,0	1	KEL	2020 81020	42,00	2022 81020	50,88
8,0	1	KEL	2020 81025	53,00	2022 81025	64,09
10,0	1	KEL	2020 81035	63,00	2022 81035	75,39
12,0	1	KEL	2020 81045	69,00	2022 81045	87,03
16,0	1	KEL	2020 81060	116,00	2022 81060	144,16
6,0	1	SKM	2020 91030	37,00	2022 91030	49,75
8,0	1	SKM	2020 91035	49,00	2022 91035	64,09
10,0	1	SKM	2020 91040	59,00	2022 91040	76,52
12,0	1	SKM	2020 91045	66,00	2022 91045	89,31
16,0	1	SKM	2020 91055	106,00	2022 91055	149,85

**WIERTŁA TREPANACYJNE Z ZĘBAMI**

**seria 5050**

55mm	PLN netto/szt.	kod
12/55mm HM	158,30 zł	5050 1200
13/55mm HM	158,30 zł	5050 1300
14/55mm HM	158,30 zł	5050 1400
15/55mm HM	158,30 zł	5050 1500
16/55mm HM	158,30 zł	5050 1600
17/55mm HM	158,30 zł	5050 1700
18/55mm HM	158,30 zł	5050 1800
19/55mm HM	158,30 zł	5050 1900
20/55mm HM	158,30 zł	5050 2000
21/55mm HM	163,20 zł	5050 2100
22/55mm HM	163,20 zł	5050 2200
23/55mm HM	163,20 zł	5050 2300
24/55mm HM	163,20 zł	5050 2400
25/55mm HM	163,20 zł	5050 2500
26/55mm HM	173,00 zł	5050 2600
27/55mm HM	173,30 zł	5050 2700
28/55mm HM	173,30 zł	5050 2800
29/55mm HM	173,30 zł	5050 2900
30/55mm HM	173,30 zł	5050 3000
31/55mm HM	203,50 zł	5050 3100
32/55mm HM	203,50 zł	5050 3200
33/55mm HM	203,50 zł	5050 3300
34/55mm HM	203,50 zł	5050 3400
35/55mm HM	203,50 zł	5050 3500
36/55mm HM	232,50 zł	5050 3600
37/55mm HM	232,90 zł	5050 3700
38/55mm HM	232,90 zł	5050 3800

55mm	PLN netto/szt.	kod
39/55mm HM	232,90 zł	5050 3900
40/55mm HM	232,90 zł	5050 4000
41/55mm HM	265,62 zł	5050 4100
42/55mm HM	280,80 zł	5050 4200
43/55mm HM	265,62 zł	5050 4300
44/55mm HM	265,62 zł	5050 4400
45/55mm HM	280,80 zł	5050 4500
46/55mm HM	285,57 zł	5050 4600
47/55mm HM	285,57 zł	5050 4700
48/55mm HM	285,57 zł	5050 4800
49/55mm HM	285,57 zł	5050 4900
50/55mm HM	319,60 zł	5050 5000
51/55mm HM	327,75 zł	5050 5100
52/55mm HM	335,45 zł	5050 5200
53/55mm HM	345,71 zł	5050 5300
54/55mm HM	357,11 zł	5050 5400
55/55mm HM	364,80 zł	5050 5500
56/55mm HM	377,63 zł	5050 5600
57/55mm HM	386,75 zł	5050 5700
58/55mm HM	393,87 zł	5050 5800
59/55mm HM	401,00 zł	5050 5900
60/55mm HM	407,84 zł	5050 6000
62/55mm HM	434,91 zł	5050 6200
65/55mm HM	481,08 zł	5050 6500
70/55mm HM	544,64 zł	5050 7000
75/55mm HM	579,98 zł	5050 7500
80/55mm HM	620,16 zł	5050 8000

**PILOTY**

55mm	PLN netto/szt.	kod
6,34x106mm 12-17mm	17,40 zł	5000 5050
7,98x108mm od 18mm	28,80 zł	5000 5051
7,98x115mm od 70mm	32,00 zł	5000 5052

**WIERTŁA TREPANACYJNE**

**seria 5010**

30mm	PLN netto/szt.	kod
12/30mm HSS	68,50 zł	5010 1200
13/30mm HSS	68,50 zł	5010 1300
14/30mm HSS	70,40 zł	5010 1400
15/30mm HSS	70,40 zł	5010 1500
16/30mm HSS	73,30 zł	5010 1600
17/30mm HSS	73,30 zł	5010 1700
18/30mm HSS	76,70 zł	5010 1800
19/30mm HSS	76,70 zł	5010 1900
20/30mm HSS	82,50 zł	5010 2000
21/30mm HSS	82,50 zł	5010 2100
22/30mm HSS	97,90 zł	5010 2200
23/30mm HSS	97,90 zł	5010 2300
24/30mm HSS	101,40 zł	5010 2400
25/30mm HSS	101,40 zł	5010 2500
26/30mm HSS	107,50 zł	5010 2600
27/30mm HSS	107,50 zł	5010 2700
28/30mm HSS	119,50 zł	5010 2800
30/30mm HSS	125,20 zł	5010 3000
31/30mm HSS	132,07 zł	5010 3100
32/30mm HSS	138,18 zł	5010 3200
33/30mm HSS	138,18 zł	5010 3300
34/30mm HSS	145,70 zł	5010 3400
35/30mm HSS	145,70 zł	5010 3500
36/30mm HSS	165,21 zł	5010 3600
37/30mm HSS	171,55 zł	5010 3700
38/30mm HSS	184,24 zł	5010 3800
39/30mm HSS	184,24 zł	5010 3900
40/30mm HSS	202,10 zł	5010 4000
Pilot 6,34x77mm	15,10 zł	5000 5010

**ADAPTERY**

Nazwa	PLN netto/szt.	kod
MK2 - Weldon	151,00 zł	5000 0010
MK3 - Weldon	162,10 zł	5000 0020
MK2 - Weldon chłodz. wewn.	289,10 zł	5000 0030
MK3 - Weldon chłodz. wewn.	305,90 zł	5000 0040

**seria 5020**

55mm	PLN netto/szt.	kod
12/55mm HSS	86,70 zł	5020 1200
13/55mm HSS	86,70 zł	5020 1300
14/55mm HSS	89,50 zł	5020 1400
15/55mm HSS	89,50 zł	5020 1500
16/55mm HSS	92,00 zł	5020 1600
17/55mm HSS	92,00 zł	5020 1700
18/55mm HSS	95,80 zł	5020 1800
19/55mm HSS	95,80 zł	5020 1900
20/55mm HSS	101,90 zł	5020 2000
21/55mm HSS	101,90 zł	5020 2100
22/55mm HSS	115,90 zł	5020 2200
23/55mm HSS	115,90 zł	5020 2300
24/55mm HSS	122,60 zł	5020 2400
25/55mm HSS	122,60 zł	5020 2500
26/55mm HSS	133,40 zł	5020 2600
27/55mm HSS	133,40 zł	5020 2700
28/55mm HSS	145,30 zł	5020 2800
29/55mm HSS	145,30 zł	5020 2900
30/55mm HSS	152,50 zł	5020 3000
31/55mm HSS	152,50 zł	5020 3100
32/55mm HSS	163,20 zł	5020 3200
33/55mm HSS	163,20 zł	5020 3300
34/55mm HSS	174,10 zł	5020 3400
35/55mm HSS	174,10 zł	5020 3500
36/55mm HSS	197,00 zł	5020 3600
37/55mm HSS	204,80 zł	5020 3700
38/55mm HSS	217,40 zł	5020 3800
39/55mm HSS	217,40 zł	5020 3900
40/55mm HSS	237,70 zł	5020 4000
41/55mm HSS	250,98 zł	5020 4100
42/55mm HSS	271,43 zł	5020 4200
43/55mm HSS	271,43 zł	5020 4300
44/55mm HSS	298,22 zł	5020 4400
45/55mm HSS	298,22 zł	5020 4500
46/55mm HSS	320,54 zł	5020 4600
47/55mm HSS	320,54 zł	5020 4700
48/55mm HSS	338,40 zł	5020 4800
49/55mm HSS	338,40 zł	5020 4900
50/55mm HSS	381,88 zł	5020 5000
52/55mm HSS	400,21 zł	5020 5200
Pilot 6,34x103mm	17,40 zł	5000 5020

**WIERTŁA DIN 340**

HSS

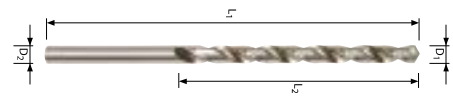

**seria 1050**

Ø mm	opak. szt.	PLN netto/szt.	Ø mm	opak. szt.	PLN netto/szt.	Ø mm	opak. szt.	PLN netto/szt.
1,0	10	2,70	4,5	10	4,60	9,0	5	16,70
1,5	10	2,70	5,0	10	5,20	9,5	5	18,00
2,0	10	2,70	5,2	10	6,70	10,0	5	20,00
2,5	10	2,80	5,5	10	6,70	10,2	5	23,40
3,0	10	2,90	6,0	10	7,50	10,5	5	23,80
3,2	10	3,70	6,5	10	8,40	11,0	5	27,00
3,3	10	3,70	7,0	10	10,00	11,5	5	30,20
3,5	10	3,70	7,5	5	11,00	12,0	5	33,00
4,0	10	3,80	8,0	5	13,10	12,5	5	35,80
4,1	10	4,30	8,5	5	14,40	13,0	5	36,00
4,2	10	4,30						

**WIERTŁA dwustronne**

HSS

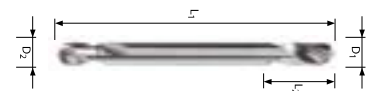

**seria 1043**

Ø mm	opak. szt.	PLN netto/szt.	Ø mm	opak. szt.	PLN netto/szt.	Ø mm	opak. szt.	PLN netto/szt.
2,0	10	1,80	4,0	10	3,10	5,0	10	4,00
2,5	10	1,80	4,1	10	3,10	5,2	10	4,70
3,0	10	2,50	4,2	10	3,10	5,5	10	4,70
3,2	10	2,60	4,3	10	3,30	6,0	10	5,60
3,3	10	2,65	4,5	10	3,40	6,5	10	6,90
3,5	10	2,60						

**WIERTŁA dwustronne**

HSSE Co 5

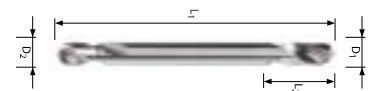

**seria 1044**

Ø mm	opak. szt.	PLN netto/szt.	Ø mm	opak. szt.	PLN netto/szt.	Ø mm	opak. szt.	PLN netto/szt.
2,0	10	4,20	3,5	10	5,80	5,0	10	7,20
2,5	10	4,40	4,0	10	5,90	5,2	10	8,50
3,0	10	4,50	4,1	10	6,80	5,5	10	8,90
3,2	10	4,60	4,2	10	6,90	6,0	10	9,10
3,3	10	5,50	4,5	10	7,00	6,5	10	11,40

**WIERTŁA podtaczane**

HSS

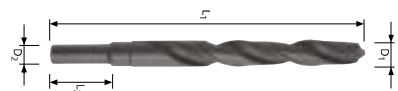

**seria 1020**

Ø mm	opak. szt.	PLN netto/szt.	Ø mm	opak. szt.	PLN netto/szt.	Ø mm	opak. szt.	PLN netto/szt.
12,0	1	16,10	15,0	1	26,37	18,0	1	34,05
12,5	1	16,10	15,5	1	26,56	18,5	1	34,59
13,0	1	16,10	16,0	1	28,51	19,0	1	34,59
13,5	1	20,35	16,5	1	28,51	19,5	1	37,70
14,0	1	20,74	17,0	1	28,51	20,0	1	40,93
14,5	1	22,18	17,5	1	34,05			

www.bausmet.pl

PRZYKŁAD ZAMAWIANIA:

seria 1050 Ø 3,0mm 10szt

**WIERTŁA DIN 345**

HSS

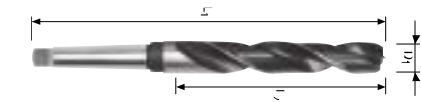

**seria 1060**

Ø mm	opak. szt.	PLN netto/szt.	Ø mm	opak. szt.	PLN netto/szt.	Ø mm	opak. szt.	PLN netto/szt.
12,0	1	18,67	18,5	1	37,79	25,0	1	70,87
12,5	1	20,24	19,0	1	37,24	25,5	1	76,84
13,0	1	21,35	19,5	1	41,52	26,0	1	78,17
13,5	1	24,77	20,0	1	40,91	26,5	1	78,17
14,0	1	25,98	20,5	1	48,20	27,0	1	82,06
14,5	1	29,96	21,0	1	47,49	27,5	1	83,03
15,0	1	29,52	21,5	1	51,61	28,0	1	83,03
15,5	1	32,02	22,0	1	50,85	28,5	1	87,73
16,0	1	31,55	22,5	1	56,40	29,0	1	88,91
16,5	1	33,93	23,0	1	55,57	29,5	1	96,06
17,0	1	33,43	23,5	1	63,68	30,0	1	96,06
17,5	1	36,08	24,0	1	66,21			
18,0	1	35,55	24,5	1	69,25			

**WIERTŁA DIN 345 szlifowane**

HSS

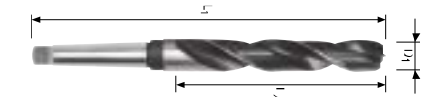

**seria 1065**

Ø mm	opak. szt.	PLN netto/szt.	Ø mm	opak. szt.	PLN netto/szt.	Ø mm	opak. szt.	PLN netto/szt.
10,0	1	24,30	22,5	1	82,94	39,0	1	303,88
10,5	1	24,30	23,0	1	82,94	40,0	1	315,94
11,0	1	26,10	23,5	1	93,64	41,0	1	347,98
11,5	1	26,64	24,0	1	98,82	42,0	1	365,80
12,0	1	27,86	24,5	1	101,84	43,0	1	377,93
12,5	1	29,77	25,0	1	104,22	44,0	1	390,92
13,0	1	31,86	25,5	1	113,00	45,0	1	410,54
13,5	1	36,43	26,0	1	114,95	46,0	1	423,00
14,0	1	38,77	26,5	1	114,95	47,0	1	444,20
14,5	1	44,06	27,0	1	120,67	48,0	1	460,51
15,0	1	44,06	27,5	1	122,11	49,0	1	481,97
15,5	1	47,09	28,0	1	122,11	50,0	1	642,67
16,0	1	47,09	28,5	1	129,02	51,0	1	663,91
16,5	1	49,90	29,0	1	130,75	52,0	1	674,68
17,0	1	49,90	29,5	1	141,26	53,0	1	723,02
17,5	1	53,06	30,0	1	141,26	54,0	1	744,23
18,0	1	53,06	30,5	1	151,99	55,0	1	744,23
18,5	1	55,58	31,0	1	160,52	56,0	1	781,45
19,0	1	55,58	32,0	1	192,60	57,0	1	819,22
19,5	1	61,06	33,0	1	202,79	58,0	1	819,22
20,0	1	61,06	34,0	1	215,53	59,0	1	840,64
20,5	1	70,88	35,0	1	234,94	60,0	1	887,34
21,0	1	70,88	36,0	1	254,45	65,0	1	1 529,40
21,5	1	75,89	37,0	1	275,98	70,0	1	1 773,65
22,0	1	75,89	38,0	1	284,22			

www.bausmet.pl

PRZYKŁAD ZAMAWIANIA:

seria 1060 Ø 20,0mm 1szt  
seria 1065 Ø 20,0mm 1szt



**WIERTŁA DIN 338**

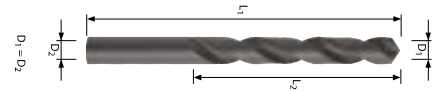

**seria 1000**

Ø mm	opak. szt.	PLN netto/szt.	Ø mm	opak. szt.	PLN netto/szt.	Ø mm	opak. szt.	PLN netto/szt.
1,0	10	0,79	5,0	10	1,31	9,0	10	4,20
1,1	10	0,79	5,1	10	1,97	9,1	10	5,20
1,2	10	0,79	5,2	10	1,97	9,2	10	5,20
1,3	10	0,79	5,3	10	1,98	9,3	10	5,20
1,4	10	0,79	5,4	10	1,98	9,4	10	5,20
1,5	10	0,79	5,5	10	1,98	9,5	10	5,20
1,6	10	0,79	5,6	10	1,98	9,6	5	5,60
1,7	10	0,79	5,7	10	1,98	9,7	5	5,60
1,8	10	0,79	5,8	10	1,98	9,8	5	5,60
1,9	10	0,79	5,9	10	1,98	9,9	5	5,60
2,0	10	0,79	6,0	10	1,72	10,0	5	5,45
2,1	10	0,94	6,1	10	2,32	10,2	5	6,63
2,2	10	0,94	6,2	10	2,24	10,5	5	7,09
2,3	10	0,94	6,3	10	2,32	11,0	5	7,89
2,4	10	0,94	6,4	10	2,24	11,5	5	8,00
2,5	10	0,96	6,5	10	2,22	12,0	5	9,31
2,6	10	1,01	6,6	10	2,89	12,5	5	10,39
2,7	10	1,01	6,7	10	2,89	13,0	5	10,68
2,8	10	1,01	6,8	10	2,89	13,5	1	12,39
2,9	10	1,01	6,9	10	2,89	14,0	1	12,39
3,0	10	0,88	7,0	10	2,89	14,5	1	14,10
3,1	10	1,14	7,1	10	3,11	15,0	1	15,56
3,2	10	1,06	7,2	10	3,11	15,5	1	16,46
3,3	10	1,14	7,3	10	3,11	16,0	1	17,46
3,4	10	1,14	7,4	10	3,11	16,5	1	17,70
3,5	10	1,06	7,5	10	3,18	17,0	1	17,70
3,6	10	1,31	7,6	10	3,59	17,5	1	21,67
3,7	10	1,31	7,7	10	3,59	18,0	1	21,67
3,8	10	1,31	7,8	10	3,59	18,5	1	21,67
3,9	10	1,31	7,9	10	3,59	19,0	1	24,60
4,0	10	1,06	8,0	10	3,26	19,5	1	24,60
4,1	10	1,29	8,1	10	3,78	20,0	1	26,60
4,2	10	1,29	8,2	10	3,88			
4,3	10	1,41	8,3	10	3,78			
4,4	10	1,41	8,4	10	3,88			
4,5	10	1,39	8,5	10	3,78			
4,6	10	1,62	8,6	10	4,20			
4,7	10	1,62	8,7	10	4,12			
4,8	10	1,62	8,8	10	4,12			
4,9	10	1,62	8,9	10	4,12			

**WIERTŁA DIN 338**



**seria 1010**

Ø mm	opak. szt.	PLN netto/szt.	Ø mm	opak. szt.	PLN netto/szt.	Ø mm	opak. szt.	PLN netto/szt.
1,0	10	3,94	5,0	10	5,20	10,5	5	24,34
1,1	10	3,94	5,1	10	6,50	11,0	5	30,22
1,2	10	3,94	5,2	10	6,50	11,5	5	35,46
1,3	10	3,94	5,3	10	6,50	12,0	5	36,68
1,5	10	3,94	5,4	10	8,20	12,5	5	45,40
1,6	10	3,94	5,5	10	7,45	13,0	5	47,42
1,7	10	3,94	5,6	10	8,40	14,0	1	52,60
1,8	10	3,94	5,7	10	8,40	15,0	1	77,90
1,9	10	3,94	5,8	10	8,40	16,0	1	93,65
2,0	10	3,20	5,9	10	8,40			
2,1	10	3,60	6,0	10	6,85			
2,2	10	3,60	6,1	10	9,42			
2,3	10	3,60	6,2	10	9,42			
2,4	10	3,90	6,4	10	10,10			
2,5	10	3,35	6,5	10	8,80			
2,6	10	3,90	6,6	10	10,10			
2,7	10	4,00	6,8	10	11,00			
2,8	10	4,00	6,9	10	11,00			
2,9	10	4,20	7,0	10	9,50			
3,0	10	3,25	7,2	10	13,30			
3,1	10	4,10	7,3	10	13,30			
3,2	10	3,55	7,4	10	13,30			
3,3	10	4,20	7,5	10	12,50			
3,4	10	4,80	7,6	10	14,10			
3,5	10	4,45	7,7	10	14,10			
3,6	10	4,80	7,8	10	14,10			
3,7	10	4,80	7,9	10	14,10			
3,8	10	5,10	8,0	10	13,65			
3,9	10	5,20	8,1	10	15,30			
4,0	10	4,30	8,2	10	15,30			
4,1	10	5,20	8,4	10	16,00			
4,2	10	4,40	8,5	10	15,10			
4,3	10	5,80	8,7	10	16,40			
4,5	10	5,42	8,8	10	16,40			
4,6	10	5,80	9,0	10	17,10			
4,7	10	5,80	9,5	10	18,90			
4,8	10	5,96	10,0	5	20,10			
4,9	10	6,20	10,2	5	24,34			

w w w . b a u s m e t . p l

**PRZYKŁAD ZAMAWIANIA:**

seria 1000 Ø 3,0mm 10szt

w w w . b a u s m e t . p l

**PRZYKŁAD ZAMAWIANIA:**

seria 1010 Ø 3,0mm 10szt

**WIERTŁA DIN 338**

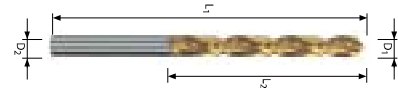

**seria 1006**

Ø mm	opak. szt.	PLN netto/szt.	Ø mm	opak. szt.	PLN netto/szt.	Ø mm	opak. szt.	PLN netto/szt.
0,3	10	2,66	4,0	10	2,40	9,5	10	11,10
0,4	10	2,66	4,1	10	2,89	10,0	5	15,12
0,5	10	2,66	4,2	10	2,89	10,2	5	15,12
0,6	10	2,66	4,5	10	2,89	10,5	5	15,12
0,7	10	2,66	5,0	10	3,20	11,0	5	17,86
0,8	10	2,66	5,5	10	4,00	11,5	5	19,00
0,9	10	2,66	6,0	10	4,18	12,0	5	20,63
1,0	10	1,73	6,5	10	5,37	12,5	5	24,24
1,5	10	1,73	7,0	10	6,40	13,0	5	25,00
2,0	10	1,73	7,5	10	6,62			
2,5	10	1,87	8,0	10	7,49			
3,0	10	1,80	8,5	10	8,70			
3,2	10	2,18	9,0	10	10,18			
3,3	10	2,18						
3,5	10	2,12						

**WIERTŁA DIN 338 szlifowane**

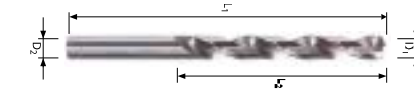

**seria 1005**

Ø mm	opak. szt.	PLN netto/szt.	Ø mm	opak. szt.	PLN netto/szt.	Ø mm	opak. szt.	PLN netto/szt.
0,3	10	2,64	4,0	10	2,38	9,5	10	11,08
0,4	10	2,64	4,1	10	2,87	10,0	5	15,10
0,5	10	2,64	4,2	10	2,87	10,2	5	15,10
0,6	10	2,64	4,3	10	2,87	10,5	5	15,10
0,7	10	2,64	4,5	10	2,87	11,0	5	17,84
0,8	10	2,64	4,6	10	3,38	11,5	5	18,98
0,9	10	2,64	4,7	10	3,38	12,0	5	20,61
1,0	10	1,71	4,8	10	3,38	12,5	5	24,22
1,1	10	1,76	4,9	10	3,38	13,0	5	24,98
1,2	10	1,76	5,0	10	3,18	14,0	1	41,72
1,3	10	1,76	5,1	10	3,98	15,0	1	52,34
1,5	10	1,71	5,2	10	3,98	16,0	1	64,47
1,6	10	1,76	5,3	10	3,98			
1,7	10	1,76	5,4	10	3,98			
1,8	10	1,76	5,5	10	3,98			
1,9	10	1,76	5,6	10	4,27			
2,0	10	1,71	5,7	10	4,27			
2,1	10	1,90	5,8	10	4,27			
2,2	10	1,90	5,9	10	4,27			
2,3	10	1,90	6,0	10	4,16			
2,4	10	1,90	6,1	10	5,35			
2,5	10	1,85	6,2	10	5,35			
2,6	10	1,90	6,4	10	5,35			
2,7	10	1,90	6,5	10	5,35			
2,8	10	1,90	6,6	10	6,38			
2,9	10	1,90	6,8	10	6,38			
3,0	10	1,78	6,9	10	6,38			
3,1	10	2,16	7,0	10	6,38			
3,2	10	2,16	7,2	10	6,60			
3,3	10	2,16	7,5	10	6,60			
3,4	10	2,16	8,0	10	7,47			
3,5	10	2,10	8,1	10	8,57			
3,6	10	2,50	8,2	10	8,57			
3,7	10	2,50	8,4	10	8,68			
3,8	10	2,50	8,5	10	8,68			
3,9	10	2,50	9,0	10	10,16			

www.baumet.pl

**PRZYKŁAD ZAMAWIANIA:**

seria 1006 Ø 3,0mm 10szt

www.baumet.pl

**PRZYKŁAD ZAMAWIANIA:**

seria 1005 Ø 3,0mm 10szt

ZESTAWY WIERTEŁ HSS DIN 338



HSS

opis	opak. szt.	PLN netto/szt.	kod
Zestaw HSS-R wiertła walcowane 19 szt Ø 1,0 – 10,0 x 0,5mm	1	35,00	1901
Zestaw HSS-R wiertła walcowane 25 szt Ø 1,0 – 13,0 x 0,5mm	1	70,00	1902



HSS

opis	opak. szt.	PLN netto/szt.	kod
Zestaw HSS-G wiertła szlifowane 19 szt Ø 1,0 – 10,0 x 0,5mm	1	68,00	1903
Zestaw HSS-G wiertła szlifowane 25 szt Ø 1,0 – 13,0 x 0,5mm	1	142,00	1904



HSS

TiN

opis	opak. szt.	PLN netto/szt.	kod
Zestaw HSS-G wiertła szlifowane TiN 19 szt Ø 1,0 – 10,0 x 0,5mm	1	75,00	1905
Zestaw HSS-G wiertła szlifowane TiN 25 szt Ø 1,0 – 13,0 x 0,5mm	1	150,00	1906



HSSE

Co 5

opis	opak. szt.	PLN netto/szt.	kod
Zestaw HSS-G Co5 wiertła kobaltowe 19 szt Ø 1,0 – 10,0 x 0,5mm	1	128,00	1907
Zestaw HSS-G Co5 wiertła kobaltowe 25 szt Ø 1,0 – 13,0 x 0,5mm	1	285,00	1908



HSS

TiN

opis	opak. szt.	PLN netto/szt.	kod
Zestaw HSS TiN wiertła stopniowe - 3szt.	1	205,00	1909



HSS

opis	opak. szt.	PLN netto/szt.	kod
Zestaw HSS pogłębiacze DIN 335 - 6szt.	1	215,00	1910

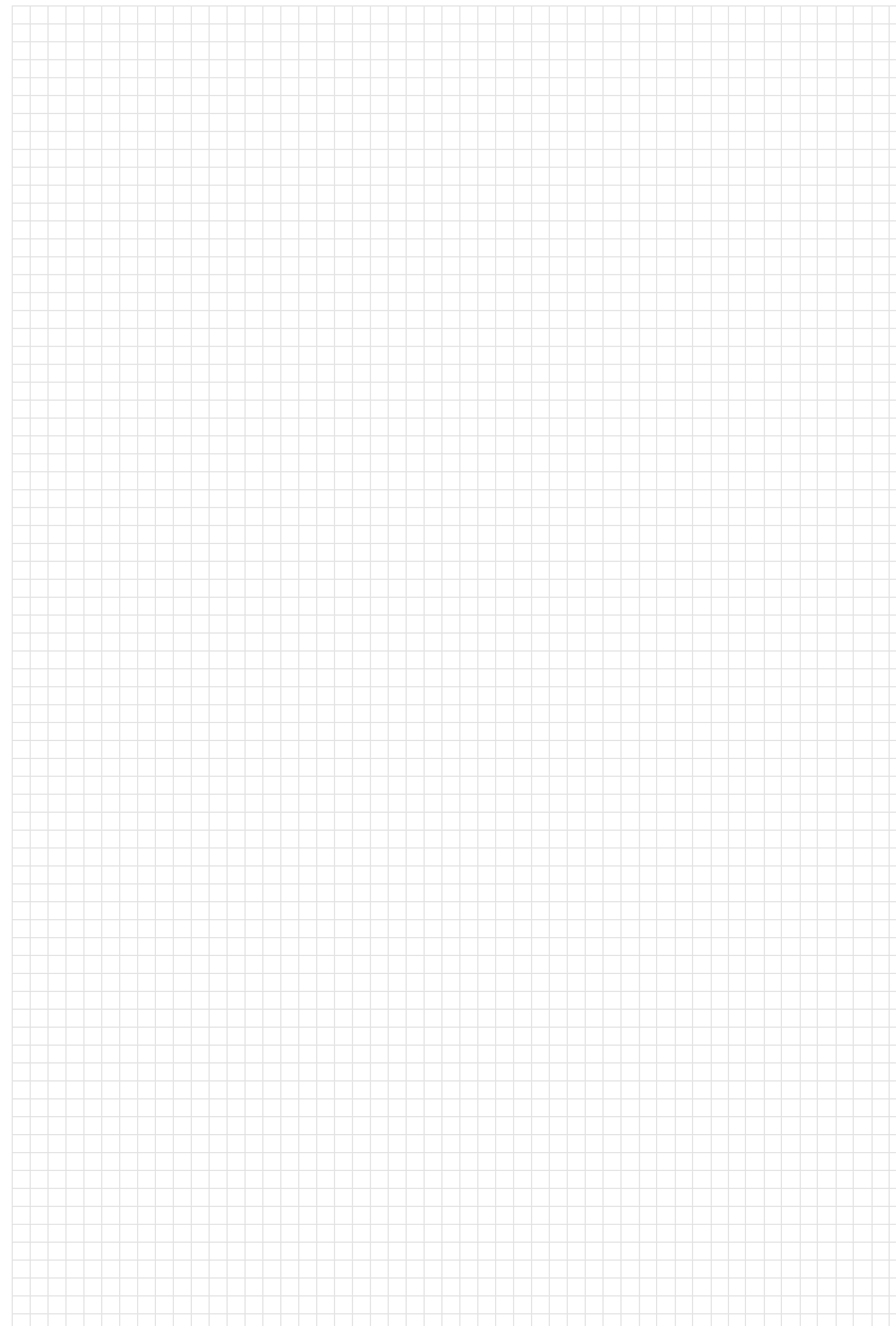

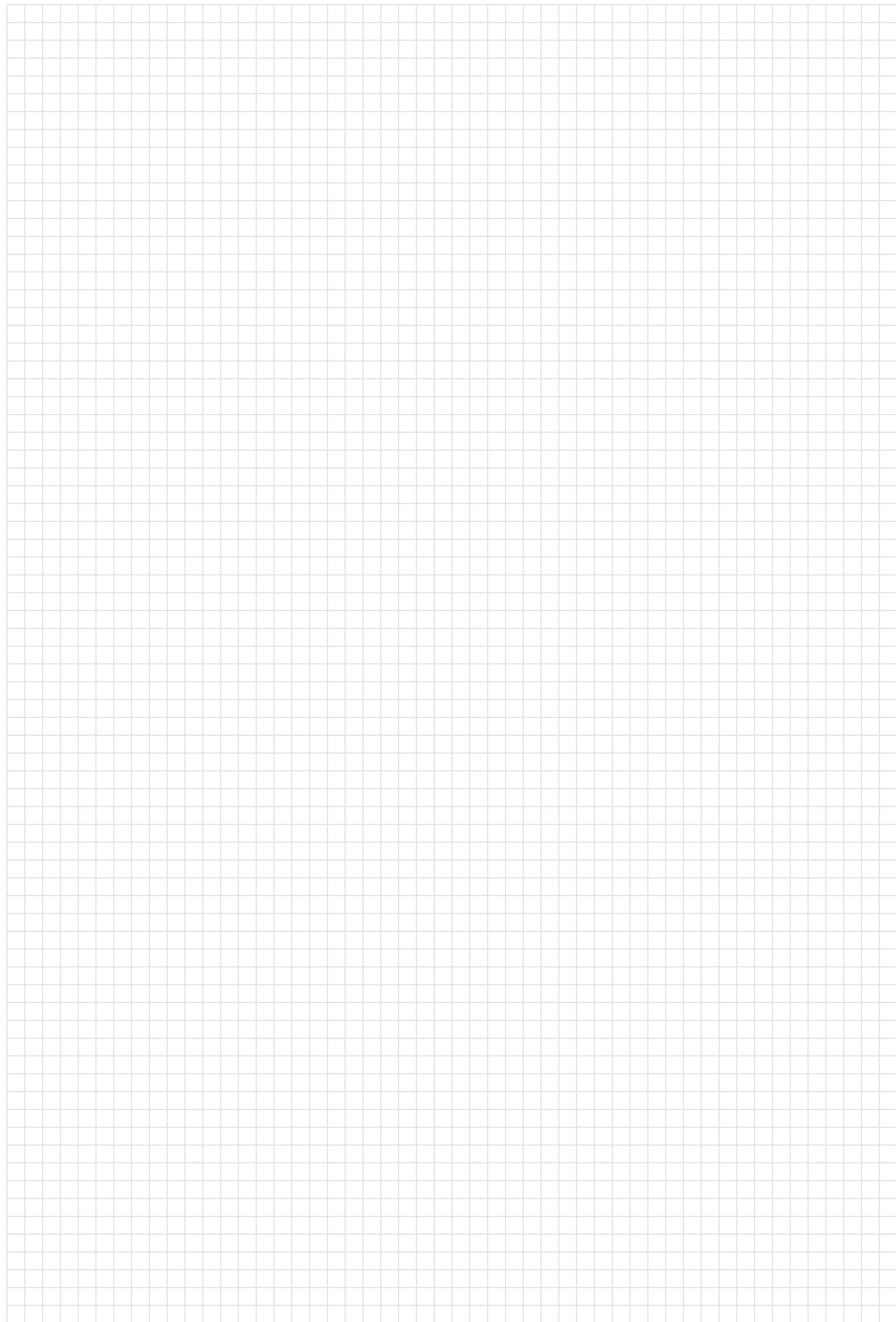



P.H.U. BAUSMET Sylwia Miglas  
42-216 Częstochowa  
ul. Jagiellońska 75  
tel: +48 667 97 02 85  
fax: 34 366 24 93  
e-mail: sklep@bausmet.pl  
sklep: www.bausmet.pl



Informacje znajdujące się w niniejszym katalogu nie są prawnie wiążące i nie stanowią oferty handlowej w rozumieniu art. 66 Kodeksu cywilnego z dnia 23 kwietnia 1964 roku (Dz. U. Nr 16, poz. 93) oraz innych przepisów prawa, mają jedynie charakter poglądowy i informacyjny stanowiąc zaproszenie do negocjacji. Z uwagi na mogące wystąpić zróżnicowanie towaru pod względem kształtu, kolorystyki, rozmiaru oraz innych parametrów wizualnych i technicznych indywidualizacja zamówienia następuje każdorazowo w drodze zawieranej z Klientem umowy. Klient, składając zamówienie, składa jednocześnie propozycję zawarcia umowy.